

# CENEX TOTAL PROTECTION PLAN®

---

Unsurpassed coverage for  
peace of mind



## **INDUSTRY-LEADING COVERAGE OF YOUR MOST VALUABLE EQUIPMENT INVESTMENTS**

For generations, agricultural producers have chosen the superior protection and performance of Cenex® Ruby Fieldmaster® Premium Diesel Fuel and Cenex lubricants, to ensure their critical equipment is ready when it's needed most. Season after season, they've experienced dependable performance and extended equipment life, plus the peace of mind in knowing their operation's most valuable assets are protected.

As you invest in equipment technology for your operation, consider the importance of protecting that significant investment with quality fuels, lubricants and the Cenex Total Protection Plan®. This unique warranty program is available for both new and used equipment to extend protection well beyond the original equipment manufacturers' warranty.

The industry's leading warranty program grew from an unwavering commitment to quality and dependability. A protection plan like no other, the Cenex Total Protection Plan ensures that only high-quality energy products are used to give you the power you need to keep your business running like a well-oiled machine.

Extend the life of your equipment and protect it for up to 10 years or 10,000 hours with the best warranty in agriculture – the Cenex Total Protection Plan.



## A PROTECTION PLAN LIKE NO OTHER, THE CENEX TOTAL PROTECTION PLAN®:

- Covers new equipment for up to 10 years or 10,000 hours and used equipment for up to 8 years or 8,000 hours
- Extends protection above and beyond original equipment manufacturers' warranties
- Provides comprehensive protection for just \$799
- Earns you \$200 in Cenex® products upon warranty activation
- Has no deductible
- Includes periodic maintenance reminders to help keep your equipment in top condition
- Helps avoid downtime through LubeScan® Used Oil Analysis fluid sample reports that provide insight into internal equipment condition
- Transfers to purchasers of your equipment

## THE PLAN IS SIMPLE.

1. Enroll equipment by visiting [TPPWarranty.Cenex.com](http://TPPWarranty.Cenex.com).
2. Complete the application and submit payment online.
3. Use approved Covered Fluids (exclusively Cenex® products), industry standard filters, and perform required LubeScan Used Oil Analysis sampling.
4. Submit a sample from each covered component's fluid change or drain to LubeScan, at minimum annually. Use the report to help perform timely maintenance and avoid downtime.
5. Retain proofs-of-purchase for all Cenex products.
6. Avoid actions, such as equipment abuse or unauthorized product use, which could void coverage.
7. Follow the *5 Steps to Maintain Coverage* that you will receive in your official Approval Welcome Kit when your warranty is activated to keep your warranty compliant.



# UNMATCHED COVERAGE OF YOUR NEW EQUIPMENT INVESTMENTS

Extend the life of your equipment with the best warranty program in agriculture and forestry. The Cenex Total Protection Plan® covers specified components of NEW agricultural equipment for up to 10 years or 10,000 hours.

For superior protection and performance, select synthetic oils and get 10 years/10,000 hours of engine coverage when you use Cenex® Maxtron® Enviro-EDGE® or Maxtron DEO lubricants with Cenex Ruby Fieldmaster® Premium Diesel Fuels.

Conventional oil users can expand engine coverage from 8 years/8,000 hours to 9 years/9,000 hours when approved Cenex Ruby Fieldmaster Premium Diesel Fuels, purchased from an authorized distributor, are used exclusively with Cenex Superlube TMS®.

## NEW EQUIPMENT COVERAGE

### AGRICULTURAL EQUIPMENT:

#### Tractors and telescopic handlers (50+ HP)\*

Component		Covered Fluid	Warranty Term
Diesel Engine	SYNTHETIC OIL	Maxtron® Enviro-EDGE® or Maxtron® DEO	10 years/10,000 hours with Cenex® Ruby Fieldmaster® products up to B20**
			9 years/9,000 hours without Cenex® Ruby Fieldmaster®
	CONVENTIONAL OIL	Superlube TMS®	9 years/9,000 hours with Cenex® Ruby Fieldmaster® products up to B20**
			8 years/8,000 hours without Cenex® Ruby Fieldmaster®
Diesel Injection Pump/High Pressure Pump		Cenex® Ruby Fieldmaster® products up to B20**	10 years/10,000 hours with Maxtron® Enviro-EDGE® or Maxtron® DEO
			9 years/9,000 hours with Superlube TMS®
Diesel Injectors		Cenex® Ruby Fieldmaster® products up to B20**	5 years/5,000 hours
Transmission/Hydraulics/Final Drive (Common Sump)	OPTION 1	Maxtron® THF+, Maxtron® Power Transmission Fluid MV or Maxtron® All-Syn HD	10 years/10,000 hours
		Qwiklift® HTB®, Power Transmission Fluid or STOU Fluid	9 years/9,000 hours
Transmission (Separate Sump)	OPTION 2	Maxtron® THF+	10 years/10,000 hours
		Qwiklift® HTB® or STOU Fluid	9 years/9,000 hours
Hydraulics (Separate Sump)	OPTION 2	Maxtron® THF+	10 years/10,000 hours
		Qwiklift® HTB® or Indol	9 years/9,000 hours
Differential/Hubs		Maxtron® GL	6 years/6,000 hours
		MP Gear Lube	5 years/5,000 hours
Hydrostats		Maxtron® THF+	10 years/10,000 hours

### AGRICULTURAL EQUIPMENT:

#### Combines, harvesters and sprayers (50+ HP)\*

Component		Covered Fluid	Warranty Term
Diesel Engine	SYNTHETIC OIL	Maxtron® Enviro-EDGE® or Maxtron® DEO	10 years/10,000 hours with Cenex® Ruby Fieldmaster® products up to B20**
			9 years/9,000 hours without Cenex® Ruby Fieldmaster®
	CONVENTIONAL OIL	Superlube TMS®	9 years/9,000 hours with Cenex® Ruby Fieldmaster® products up to B20**
			8 years/8,000 hours without Cenex® Ruby Fieldmaster®
Diesel Injection Pump/High Pressure Pump		Cenex® Ruby Fieldmaster® products up to B20**	10 years/10,000 hours with Maxtron® Enviro-EDGE® or Maxtron® DEO
			9 years/9,000 hours with Superlube TMS®
Diesel Injectors		Cenex® Ruby Fieldmaster® products up to B20**	5 years/5,000 hours

### IRRIGATION AGRICULTURAL EQUIPMENT:

#### Irrigation Engines (50+ HP)\*

Component	Covered Fluid	Warranty Term
Diesel Engine	Maxtron® Enviro-EDGE®, Maxtron® DEO, or Superlube TMS®	4 years/8,000 hours
Diesel Injection Pump/High Pressure Pump	Cenex® Ruby Fieldmaster® products up to B20**	4 years/8,000 hours
Diesel Injectors	Cenex® Ruby Fieldmaster® products up to B20**	4 years/4,000 hours
Natural Gas/LP Engine	Maxtron® PCMO, Auto Gold®, Irriflex® or N GEO	3 years/7,000 hours

### FORESTRY EQUIPMENT:

#### Forwarders, slashers, chippers, delimiters, collectors and choppers (50+ HP)\*\*

Component	Covered Fluid	Warranty Term
Diesel Engine	Maxtron® Enviro-EDGE®, Maxtron® DEO, or Superlube TMS®	4 years/6,000 hours

\*Subject to the terms set forth in the Application and Agreement, Agricultural Equipment and Agricultural Irrigation Equipment will not qualify for coverage under the Cenex Total Protection Plan® unless such equipment exclusively uses, throughout the entire coverage period, the Cenex® lubricant product(s) listed in the selected items above and, if applicable, the identified Cenex® diesel product. Components will not qualify for coverage under the Warranty unless the equipment of which they are a part is at least 50 horsepower (HP) or greater.

\*\*Cenex Total Protection Plan® coverage for these Components available through authorized Cenex® Ruby Fieldmaster® distributors only.

\*\*\*Subject to the terms set forth in the Application and Agreement, Applicant must exclusively use both a Cenex® brand engine oil product listed above and Maxtron® THF+, Qwiklift® HTB® or STOU Fluid to be eligible for the Cenex Total Protection Plan® on Forestry Equipment.

## NEW EQUIPMENT APPLICATION AND APPROVAL PROCESS

### NEW EQUIPMENT WARRANTY

#### Application Qualifiers

- Has a diesel engine with 50 horsepower or greater
- Has less than 400 hours of service
- Is no more than 6 months from acquisition

#### Irrigation Agricultural Equipment:

- Has less than 750 hours of service
- Is no more than 60 days from acquisition

#### Application Process

1. Complete and sign the New Equipment Warranty Application and Agreement of Responsibility online at [TPPWarranty.Cenex.com](http://TPPWarranty.Cenex.com).
2. Submit payment via the online platform. CHS reserves the right, in its sole discretion, to approve or disapprove any Application and Agreement submitted for approval.
3. CHS will review your Application and Agreement and notify you if it is approved by sending you an Approval Welcome Kit detailing your coverage and containing tools to assist you in maintaining your warranty coverage. A New Equipment Warranty number will be assigned for use in identifying oil samples and to expedite related correspondence.

### WARRANTY TRANSFER

#### Transferring Coverage

Agricultural equipment\* currently covered under the Cenex Total Protection Plan® warranty can be transferred when there is more than six months remaining in the warranty term, and all prior operator responsibilities have been fulfilled.

Several requirements are necessary for the warranty to be transferred to a new operator who either owns (or leases) and operates eligible equipment within the CHS Energy trade territory.

Transferee must complete the New Equipment Warranty Application for the transferred equipment. Application must be submitted online within 30 days of acquisition. The operator must fully comply with obligations outlined in the Agreement of Responsibility found in the New Equipment Warranty Application. Coverage is limited to the original warranty term.

\*Warranties on Irrigation Agricultural Equipment and Forestry Equipment are not transferable.

# WARRANTY PROTECTION FOR YOUR USED EQUIPMENT YOU CAN'T GET ANYWHERE ELSE

The only program of its kind in agriculture, the Cenex Total Protection Plan® USED Equipment Warranty covers specified components of covered agricultural tractors, telescopic handlers, combines and harvesters up to 8 years or 8,000 hours.

The Cenex Total Protection Plan Used Equipment Warranty gives you peace of mind knowing your critical equipment is protected.

## USED EQUIPMENT COVERAGE

### STANDARD COMPONENT COVERAGE:

**Tractors, telescopic handlers, combines or harvesters (50+ HP)\***

Component	Covered Fluid	Warranty Term
Diesel Engine	Maxtron® Enviro-EDGE®, Maxtron® DEO, or Supertube TMS®	8 years/8,000 hours
Diesel Injection Pump/High Pressure Pump	Cenex® Ruby Fieldmaster® products up to B20**	8 years/8,000 hours

### EXPANDED COMPONENT COVERAGE:

**Tractors, telescopic handlers (50+ HP)\***

(50+ HP diesel tractors and telescopic handlers under 2 years old, based on manufacture date, with less than 2,000 hours are eligible)

Component	Covered Fluid	Warranty Term
Diesel Injectors	Cenex® Ruby Fieldmaster® products up to B20**	5 years/5,000 hours
Transmission/Hydraulics/Final Drive (Common Sump)	<b>OPTION 1</b> Maxtron® THF+, Maxtron® Power Transmission Fluid MV, Maxtron® All-Syn HD, Qwiklift® HTB®, Power Transmission Fluid or STOU Fluid	8 years/8,000 hours
Transmission (Separate Sump)	<b>OPTION 2</b> Maxtron® THF+, Qwiklift® HTB® or STOU Fluid	8 years/8,000 hours
Hydraulics (Separate Sump)	<b>OPTION 2</b> Maxtron® THF+, Qwiklift® HTB® or Indol	8 years/8,000 hours
Differential/Hubs	Maxtron® GL	6 years/6,000 hours
	MP Gear Lube	5 years/5,000 hours
Hydrostats	Maxtron® THF+	8 years/8,000 hours

\*Subject to the terms set forth in the Application and Agreement, Agricultural Equipment will not qualify for coverage under the Cenex Total Protection Plan® unless such equipment exclusively uses, throughout the entire coverage period, the Cenex® lubricant product(s) listed in the selected items above and, if applicable, the identified Cenex® diesel product. Components will not qualify for coverage under the Warranty unless the equipment of which they are a part is at least 50 horsepower (HP) or greater.

\*\*Cenex Total Protection Plan® coverage for these Components available through authorized Cenex® Ruby Fieldmaster® distributors only.

### Coverage Length

Equipment is covered until it reaches specified years in service from date of manufacture, or it accumulates specified hours, whichever occurs first.

*For example, for 8 years/8,000 hours of coverage, if your equipment has accumulated 2 years or 1,400 hours, the remaining coverage is 6 years or 6,600 hours.*

**IMPORTANT: The used equipment plan requires two, approved LubeScan® Used Oil Analysis fluid samples within 24 months to verify equipment is in good condition before the plan is activated.**

**Please note:** The use of Cenex® Ruby Fieldmaster® Premium Diesel Fuels includes the use of Cenex Ruby Fieldmaster Seasonally Enhanced and Cenex Wintermaster®.

### Winter-blending Ruby Fieldmaster:

Cenex Total Protection Plan® holders are required to use #1 Cenex Ruby Fieldmaster when blending with Ruby Fieldmaster for seasonal purposes. The use of an untreated #1 distillate with Ruby Fieldmaster may void your coverage.

## USED EQUIPMENT APPLICATION AND APPROVAL PROCESS

### USED EQUIPMENT WARRANTY

#### Application Qualifiers

- Does not meet the requirements of “NEW”
- Has less than 8 years and 8,000 hours of service
- Has a diesel engine with 50 horsepower or greater

#### Coverage Levels Eligibility:

##### Used Equipment **Standard Component Coverage:**

Up to 8 years old from date of manufacture or 8,000 hours, whichever comes first

##### Used Equipment **Expanded Component Coverage:**

Up to 2 years old from date of manufacture or 2,000 hours, whichever comes first

#### Application Process

1. Complete and sign the Used Equipment Warranty Application and Agreement of Responsibility online at [TPPWarranty.Cenex.com](http://TPPWarranty.Cenex.com).
2. Arrange for an authorized Cenex® representative from your authorized distributor to:
  - Assist you completing an identification inspection of the equipment to be covered, and include a LubeScan® Used Oil Analysis engine oil sample for submission to CHS. If applicable, also submit LubeScan samples for the transmission and/or hydraulics if applying for Expanded Component Coverage. LubeScan Used Oil Analysis sampling kits are available from your authorized Cenex distributor.
  - Verify date of manufacture of equipment and accumulated operating hours.
3. Submit payment via the online platform. CHS reserves the right, in its sole discretion, to approve or disapprove any Application and Agreement submitted for approval.

4. CHS will test and analyze the fluid sample. If no evidence of mechanical defects in lubricated-covered components is detected, the equipment will begin a 100-hour screening period during which the equipment operator agrees to:
  - Replace all applicable Covered Fluids with approved Cenex products.
  - Operate the covered equipment in normal operating conditions.
  - Submit a second engine oil and/or transmission/hydraulic fluid sample(s) (following the 100-hour screening period) to CHS for analysis.
5. CHS will review the second set of fluid samples along with the Application and Agreement and notify you if the second set of fluid samples are approved by sending you an Approval Welcome Kit detailing your coverage and tools for maintaining warranty coverage. A Used Equipment Warranty number will be assigned for use in identifying oil samples and to expedite related correspondence.

### WARRANTY TRANSFER

#### Transferring Coverage

Agricultural equipment currently covered under the Cenex Total Protection Plan® warranty can be transferred when there is more than six months remaining in the warranty term, and all prior operator responsibilities have been fulfilled.

Several requirements are necessary for the warranty to be transferred to a new operator who either owns (or leases) and operates eligible equipment within the CHS Energy trade territory.

Transferee must complete the Used Equipment Warranty Application for the transferred equipment. Application must be submitted online within 30 days of acquisition. The operator must fully comply with obligations outlined in the Agreement of Responsibility found in the Used Equipment Warranty Application. Coverage is limited to the original warranty term.

# THE CENEX TOTAL PROTECTION PLAN® KEEPS EQUIPMENT RUNNING SO YOU CAN KEEP WORKING

Through the Cenex Total Protection Plan®, CHS will pay costs, including installation and labor, to repair or replace faulty parts that fail during normal use.

## **DIESEL ENGINE**

Coverage limited to the internal lubricated parts.

**Not Covered:** Cylinder head assembly, valves/valve guides, oil pump and oil cooler, engine block, oil seals, oil filters, turbocharger, non-lubricated parts, external parts such as vibration dampener, and hydraulic fan motors.

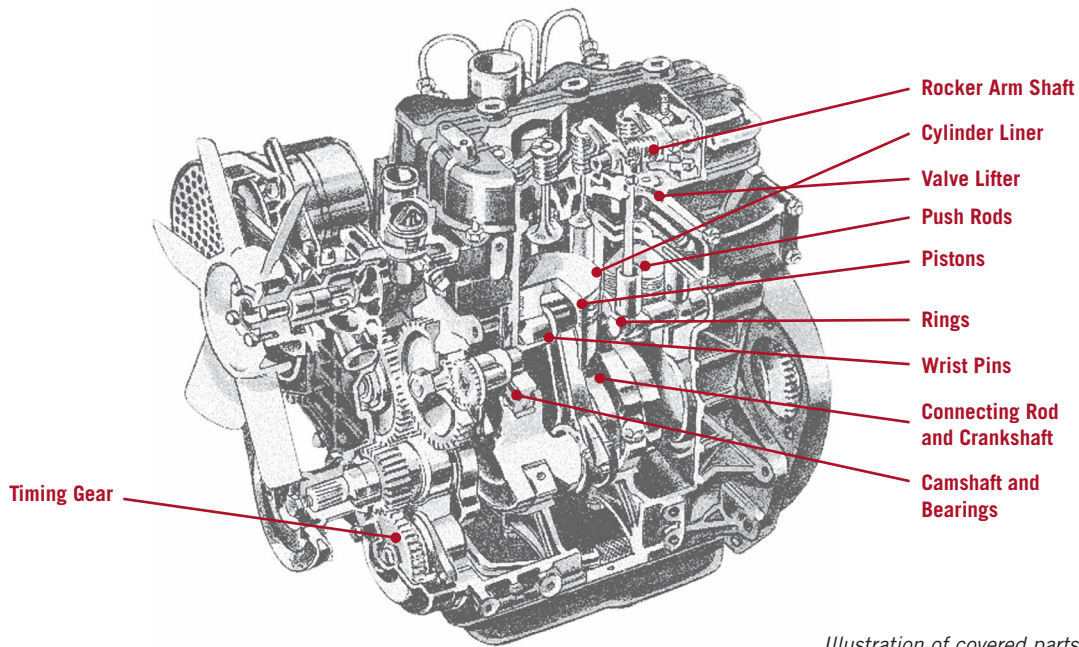

*Illustration of covered parts.*





## DIESEL FUEL INJECTION PUMP/HIGH PRESSURE PUMP AND INJECTORS

**Not Covered:** Fuel lines and filters

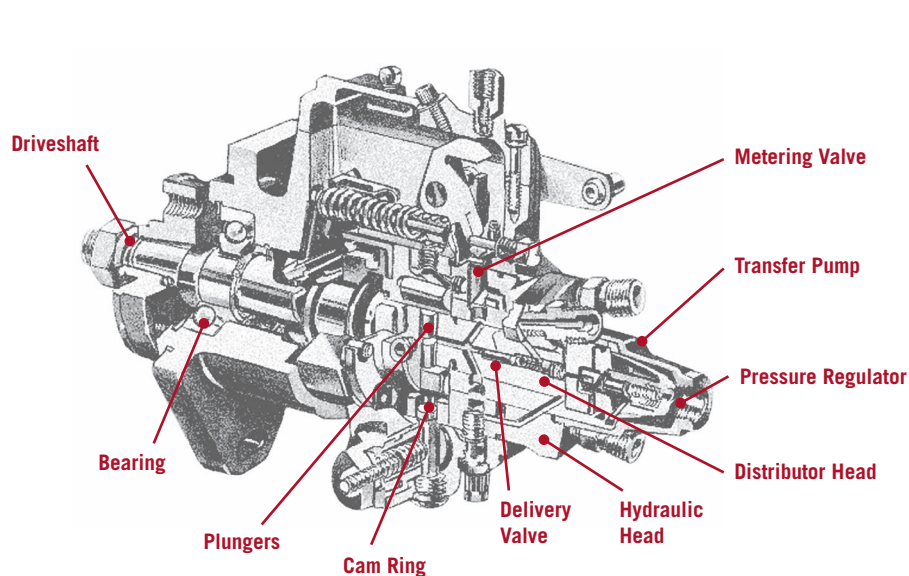

*Illustration of covered parts.*

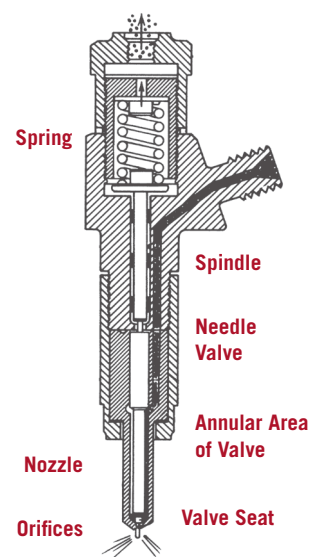

*Illustration of covered parts.*

## TRANSMISSION, HYDRAULICS, FINAL DRIVE, DIFFERENTIAL/HUBS

**Not Covered:** Auxiliary equipment, including added implements and their associated valves and pumps, bogie and idler wheels, reaction/torsion arms, hydraulic lines, hydraulic fan motors, couplers, oil coolers, cab/seating, and steering hydraulics.

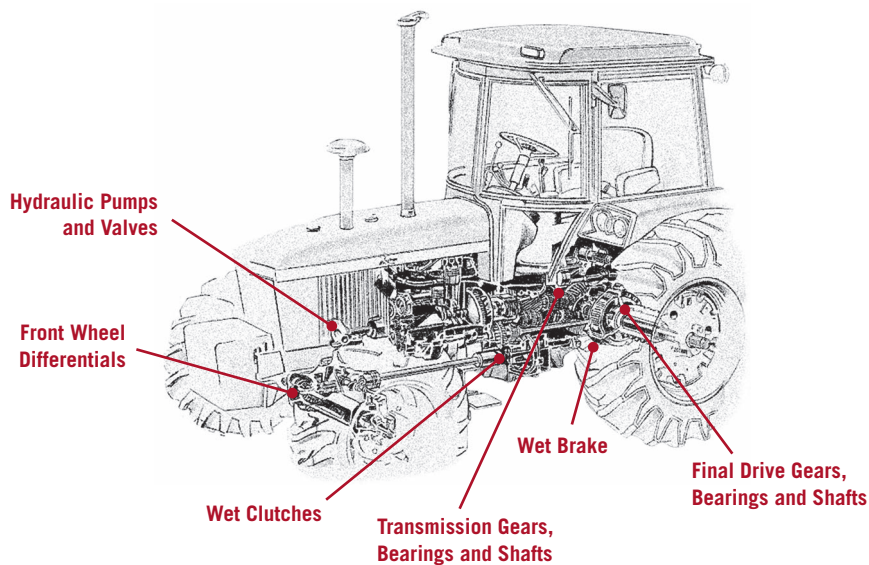

*Illustration of covered parts.*



## FREQUENTLY ASKED QUESTIONS

### 1. How often do I submit used fluid samples for each component?

A: For all components listed, used fluid samples should be submitted at **minimum** annually. In addition, consider these guidelines for submitting used fluid samples:

**Engine:** Submit used fluid sample at each oil change or drain

**Transmission/Hydraulics/Final Drive (common sump):** Submit used fluid sample every 300 hours

**Transmission only:** Submit used fluid sample every 300 hours

**Hydraulics only:** Submit used fluid sample every 300 hours

**Differentials and Hubs:** Submit used fluid sample annually

**All other covered components:** Excluding fuel-related components, submit a used fluid sample annually

### 2. Where do I submit these fluid samples?

A: Use the pre-printed ALS labels from your Approval Welcome Kit, on your Sample Identification Form (included with official LubeScan® Used Oil Analysis sample kits available from your authorized Cenex® distributor) when submitting samples to ALS Tribology to ensure that your LubeScan sample is processed correctly. Mail your filled sample container with correctly labeled and completed Sample Identification Form, and using a black mailing canister and/or mailing sleeve, to ALS Tribology lab: LubeScan, 935 Sunshine Road, Kansas City, KS, 66115-1122. Download the user-friendly ALS Webtrieve™ Mobile app for faster sample entry.

### 3. Can the warranty transfer?

A: Agricultural equipment\* currently covered under the Cenex Total Protection Plan® warranty can transfer when there is more than six months remaining in the warranty term. Several requirements are necessary for the warranty to be transferred to a new operator who either owns (or leases) and operates eligible equipment located within the CHS Energy trade territory. The Transfer and the applicable Cenex Total Protection Plan New or Used Equipment Warranty Application must be completed online within 30 days of acquisition. The operator must fully comply with obligations outlined in the Agreement of Responsibility found in the New or Used Equipment Warranty Application.

### 4. How do I make a claim?

A: Before making a claim, contact the distributor where you purchased the Cenex lubricants and Cenex Ruby Fieldmaster® Premium Diesel Fuel products used in the covered equipment. When a covered component shows signs of failure, a used oil sample and/or fuel sample are to be submitted using a LubeScan Used Oil Analysis kit or appropriate fuel kit container to CHS. Samples must be submitted before repair work is initiated. It is important to retain all replaced parts as should your claim need additional review during the claims process, CHS Technical Services may inspect failed or replaced parts. After the claim, repaired components must be refilled with Cenex Covered Fluids to ensure continued warranty coverage. A warranty holder must submit an invoice for the claim within 90 days from final invoice date.



*“It’s a great program, and it’s not hard to do.”*

*— Jim Quandt, Quandt Brothers  
Oakes, N.D.*

*“The Cenex Total Protection Plan® goes well beyond even the extended manufacturers’ warranty.”*

*— Keith Schrader  
Nerdstrand, Minn.*

*“It seems like we have quite a few expenses in farming these days. The Cenex Total Protection Plan® is a nice backup in case something unforeseen happens. It takes a little bit of the burden off your shoulders if you don’t have to always worry about the internal parts of a tractor.”*

*— Rick Chitwood  
Mayfield, Kan.*



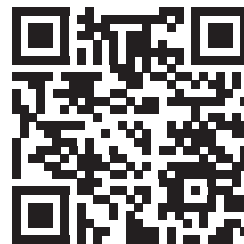
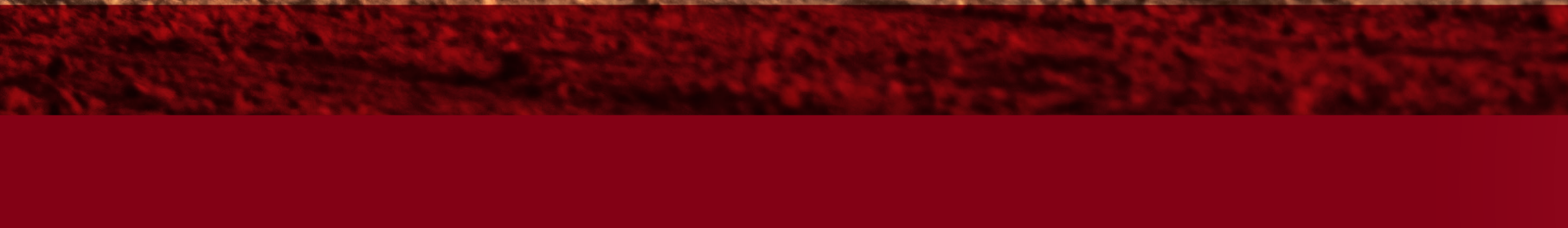

- 1) Open your phone's camera
- 2) Place camera over QR code
- 3) Visit [TPPWarranty.Cenex.com](https://TPPWarranty.Cenex.com) to complete a Warranty Application

